



Axial-Werkzeughalter Form C1 rechts

Axial toolholders form C1 right

Porte-outils axials forme C1 droite

DIN ISO 10889-1
(DIN 69880)



Verwendung:

Vorwiegend für Außenbearbeitung.
Zum Plan Einstechen.

Application:

Mainly for external machining.
For face machining.

Application:

Principalement pour usinage extérieur.
Pour carottage.

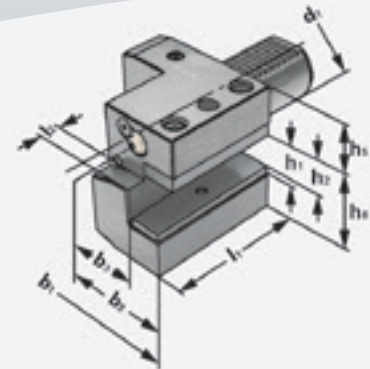

DIN ISO 10889
(DIN 69880)

C1

Bestell-Nr. Order no. Référence	Abmessung Size Dimension	d ₁	h ₁	h ₂	b ₁	b ₂	b ₃	l ₁	l ₂	h ₅	h ₆
169.41.12	C1 – 16 × 12	16	12	–	43	24	13	44	5	20	22
209.41.16	C1 – 20 × 16	20	16	12	52	27	13	50	7	25	30
259.41.16	C1 – 25 × 16	25	16	12	58	33	19	55	7	25	30
309.41.20	C1 – 30 × 20	30	20	16	70	35	17	70	10	28	38
409.41.25	C1 – 40 × 25	40	25	20	85	42,5	21	85	12,5	32,5	48
509.41.32	C1 – 50 × 32	50	32	25	100	50	26	100	16	35	60

Ausführung: Mit einstellbarer Kugelspritzdüse und Unterlegplatte
Version: With adjustable spray nozzle and shim
Version: Avec gicleur ajustable et semelle



6.40

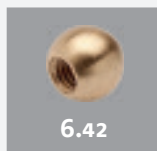

6.42